

APPROVED BY



ŠOSEJAS
KOMISIJA

LAF Racing Commission



LITHUANIAN
AUTOMOBILE
SPORT
FEDERATION

LASF Racing Commission



EESTI
RINGRAJA
KOMITEE

EAL Racing Commission

Jānis Ducmanis

Tomas Martinkus

Raimo Kulli



2025 BaTCC, NEA TECHNICAL REGULATIONS

1. GENERAL

- 1.1. These technical regulations shall come into force from 1st of March 2025 and shall remain valid until the official publication of the amendment.
- 1.2. The requirements of the FIA International Sport Code Appendix J are only applicable if there is an explicit reference to a particular article / item.
- 1.3. Car parts and their attachment must be such that they do not endanger the driver, car service personnel, third parties or third party property.
- 1.4. Everything that is not allowed in these technical regulations is forbidden. Allowed changes / redundancies should not cause or have invalid changes.
- 1.5. In the event of disagreement on the perception or application of certain points, the right to comment and clarify these technical requirements is the responsibility of the Promoter.
- 1.6. In the exceptional case, Stewards have a right to apply individual engine intake restrictor or ballast to the car for the next round of the championship.

2. DEFINITIONS

- 2.1. **Bodyshell** - the unit of metal body parts marked with a vehicle identification number (VIN), connected by welding or other fastening elements (glue, rivets), including the floor with the transmission tunnel and side sills, front and rear longitudinal beams (incl shock towers) and cross members between them (if they are not screwed in the production process), A, B, C pillars, roof panel with transverse beams, rear wings (if they are not screwed in during the production process), firewall between the cockpit and engine compartment, firewall (if provided) between the cockpit and luggage compartment, cross members and suspension mounting points (if they are not screwed in during the production process).
- 2.2. **Cockpit** - the space provided by the manufacturer for the driver and passengers, separated by the engine compartment firewall and it may be separated by luggage compartment firewall (including a shelf under the rear window). If any part in the cockpit space is separated by a fluid-tight and fire-proof container or bulkhead, this part is considered to be outside the cockpit.
- 2.3. **Original part** - part used in a serial production of the car make, or another part identical in shape and in operation (analogue) by a different manufacturer (*example: in a BMW car instead of the original BMW wishbone, SWAG, FEBI, TRW, and LEMFORDER wishbones can be used.*
- 2.4. **Serial part** - the part which is made in a serial production way in the factory (*example: in a BMW car, wishbones made by TOYOTA, VW, WISEFAB, SAMSONAS, IRP or other manufacturers can be used).*
- 2.5. **Free part** - a part that can be modified, reshaped or altered in any way or replaced by another part. Restrictions are not applied to the material or the form of the part. The part can be even removed.
- 2.6. The calculated engine capacity is the geometric engine capacity multiplied by the coefficients given in section 2.7. If the engine is not subject to a coefficient, the calculated engine capacity corresponds to the geometric capacity.
- 2.7. Coefficients for determining the calculated engine capacity:
 - Supercharged petrol engines - 1,7;
 - Rotary engines – 2,0.

3. AUTHORIZED CARS

- 3.1. Large scale series production cars, marked with factory VIN number (including CABRIO type cars with hard top in use).
- 3.2. Factory made racing cars (TCR, GT3, GT4 and other).
- 3.3. Non series production cars (with tubular frame bodywork, or semi-tubular bodywork, or monocoque bodywork).
- 3.4. Technical passport of the sporting vehicle issued by the FIA or ASN is compulsory.

4. PROHIBITED CARS

- 4.1. Cars that do not meet these technical regulations.
- 4.2. Cars with the height of less than 1100 mm or more than 1600 mm.
- 4.3. Cars with open cockpit (*example: LOTUS 7*).
- 4.4. Cars with body uncovered wheels (*example: LOTUS 7*).
- 4.5. Vehicles whose construction or equipment contain deficiencies which could endanger the crew, service personnel, third parties or third party property (as decided by the Competition Technical Commission).

5. CLASSES

- 5.1. The cars are divided into classes according to the calculated engine capacity and construction type:
 - **BTC1** – series production cars with naturally aspirated petrol engines and engine capacity up to 1600 cm³;
 - **BTC2** – series production cars with naturally aspirated petrol engines and engine capacity up to 2000 cm³;
 - **BTC3** - series production cars with naturally aspirated petrol engines and engine capacity up to 3000 cm³. Series production cars with turbocharged diesel engines and geometrical engine capacity up to **2000 cm³**;
 - **BTC4** - series production cars with calculated engine capacity up to **3500 cm³** (factory built racing cars (example: CUP cars, TCR cars) with turbocharged petrol engines and calculated engine capacity more than 3000 cm³ are prohibited);
 - **GT AM** - series production and non-series production cars (including cars with tubular frame bodywork, or semi-tubular bodywork, or monocoque bodywork) with engines located in the front (except for PORSCHE CARRERA GT3 CUP (996, 997.1, 997.2), PORSCHE CAYMAN GT4 CLUBSPORT and PORSCHE CAYMAN GT4 RS CLUBSPORT);
 - **GT PRO** – series production cars and non-series production cars (including cars with tubular frame bodywork, or semi-tubular bodywork, or monocoque bodywork). FIA homologated GT3 cars (including cars with expired homologation).

6. MINIMUM WEIGHT OF A CAR

- 6.1. Minimum racing weight (weight of the car with the driver and driver's equipment, all operating fluids and a minimum 3 litres of fuel in the tank) of a car at any time of the race (including qualifying):

Range of calculated engine capacity	Weight
BTC1, BTC2, BTC3, BTC4	
- 1300 cm ³	850 kg
1300 cm ³ - 1400 cm ³	900 kg
1400 cm ³ - 1500 cm ³	950 kg
Engines up to 1600 cm³ with two valves per cylinder	950 kg
1500 cm ³ - 1600 cm ³	1000 kg
1600 cm ³ - 1800 cm ³	1070 kg
1800 cm ³ - 2000 cm ³	1140 kg
2000 cm ³ - 2500 cm ³	1180 kg
2500 cm ³ - 3000 cm ³	1230 kg
3000 cm ³ - 3500 cm ³	1290 kg
3500 cm ³ - 4000 cm ³	1430 kg
GT AM (not for PORSCHE GT3 CUP 997.2)	
- 2500 cm ³	1080 kg
2500 cm ³ - 3000 cm ³	1130 kg
3000 cm ³ - 3500 cm ³	1190 kg
3500 cm ³ - 4000 cm ³	1250 kg
4000 cm ³ -	1310 kg
OPEL SPEEDSTER, LOTUS TYPE 116 (2,0 Turbo)	1000 kg
RENAULT MEGANE TROPHY (3,5 V6)	1050 kg
GT PRO (not for GT3 and CUP cars)	
- 2500 cm ³	960 kg
2500 cm ³ - 3000 cm ³	1020 kg
3000 cm ³ - 3500 cm ³	1080 kg
3500 cm ³ - 4000 cm ³	1140 kg
4000 cm ³ - 4500 cm ³	1200 kg
4500 cm ³ - 5000 cm ³	1260 kg
5000 cm ³ -	1320 kg

6.2. Minimum weight and BoP for GT3 or CUP cars.

Car	Weight (according to point 6.3)	Weight (according to point 6.4)	BoP
ASTON MARTIN VANTAGE GT3	1370 kg	1290 kg	-
AUDI R8 LMS GT3 EVO I	1360 kg	1280 kg	2x43 mm restrictor
AUDI R8 LMS GT3 EVO II	1390 kg	1310 kg	2x40 mm restrictor
BMW M4 GT3	1370 kg	1290 kg	-
BMW M6 GT3	1390 kg	1310 kg	-
FERRARI 488 GT3	1360 kg	1280 kg	-
FERRARI 458 ITALIA GT3 (EVO2015)	1360 kg	1280 kg	TBA
LAMBORGHINI HURACAN GT3	1390 kg	1310 kg	2x42 mm restrictor
MCLAREN 720S GT3	1310 kg	1230 kg	-
MERCEDES AMG GT3	1400 kg	1320 kg	2x38 mm restrictor
PORSCHE 911 GT3 (991 I & 991 II)	1370 kg	1290 kg	2x45 mm restrictor
LAMBORGHINI HURACAN ST	1380 kg	1300 kg	2x41 mm restrictor
PORSCHE GT3 CUP (997.2)	1280 kg	1200 kg	Non
PORSCHE GT3 CUP (991.1)	1305 kg	1225 kg	Non
PORSCHE GT3 CUP (991.2)	1305 kg	1225 kg	Non
PORSCHE GT3 CUP (992)	1375 kg	1295 kg	Non

- 6.3.** Minimum racing weight (weight of the car with the driver and driver's equipment, all operating fluids and a minimum 3 litres of fuel in the tank) of a car at any time of the race (including qualifying).
- 6.4.** Minimum weight is a weight of the car without driver, without driver's equipment and without fuel in the tank. This procedure may be used as a secondary procedure in the cases of non compliance to minimum weight set in the table 6.2 according to point 6.3).
- 6.5.** Prior to the weighing, it is forbidden to add any objects or any liquids (including fuel) to the car.
- 6.6.** Before the event it is permitted to complete weight of the car by one or several ballasts, provided that they are strong and unitary blocks, fixed by means of tools with the possibility to fix seals, placed on the floor of the cockpit.
- 6.7.** A weighing error of $\pm 0,25\%$ is applied.

7. BODYWORK

7.1. Bodyshell

- 7.1.1. The exterior of the bodywork of the base model should be maintained and recognizable.
- 7.1.2. Bodyshell must be original but may be modified in accordance with the requirements in this paragraph.
- 7.1.3. Parts and brackets (rear seat, spare wheel, wiring harnesses brackets, etc), whose function is not associated with the stiffening of the bodyshell and which do not engage parts of bodyshell, can be removed. It is allowed to modify wheel arches for a purpose of installing larger wheels.
- 7.1.4. Firewall and the floor – must be original but may be modified, but only where necessary for the installation of the seats, the exhaust system, engine and transmission units or suspension mounting. The area to be modified can not be larger than necessary for the installation of the above mentioned parts. These modifications are permitted only if the material and material thickness used is the same as the original part.
- 7.1.5. Spare wheel housing - FREE. If housing is cut off, the opening must be covered (welded, riveted, glued) with the sheet of metal or composite panel (min thickness - 1,0 mm).
- 7.1.6. Roof panel - original or can be made of composite materials (min thickness - 2,0 mm). Roof transverse member can be removed. In the case of a sunroof, the opening must be covered (welded, riveted, glued) with the same material (same material thickness) as the original or with a 2,0 mm thickness aluminum sheet or composite panel. It is allowed (recommended) to cut-off or grind-off the inner edges of the sunroof opening to reduce the possibility of the injury.
- 7.1.7. Ventilation openings, diffusers on the roof panel may be installed, with the condition that their design protects against the direct access of any objects or water to the interior of the car.
- 7.1.8. Reinforcement of the bodyshell is permitted.
- 7.1.9. Seam welding of the bodyshell is permitted.
- 7.1.10. Additional hinges, threads, and fitting are permitted.

7.2. Doors, engine bonnet and boot lid, bumpers, front fenders, grills

- 7.2.1. Front doors - original. These doors can be modified by dismantling the safety bar or can be made of composite materials. In the case of modified or composite doors, a crash box or safety foam (according to section 7.2.2) must be fitted in the driver's door (or between the roll cage and doors). Except for homologated or cup cars.
- 7.2.2. Crash box - must be made of non-combustible composite materials (minimum panel composition must comply with FIA J art 255 - 14) or made of the foam (see FIA Technical list No. 58). The panel must cover the plane from the bottom of the door to the upper edge of the roll cage side bars.
- 7.2.3. Front door window lifters - FREE.
- 7.2.4. The inner panel of the front doors - original (can be modified) or can be made of:
 - A sheet of metal (min thickness 0,5 mm);
 - A sheet of carbon fiber (min thickness 1,0 mm);
 - Other non-combustible materials (min thickness 2,0 mm).
- 7.2.5. Rear doors - original (may be modified) or made of composite materials
- 7.2.6. Rear door window lifters - FREE.
- 7.2.7. Inner panel of the rear doors - FREE.
- 7.2.8. Front doors must be openable from both inside and outside of the car.

- 7.2.9. Engine bonnet and boot lid - original (may be modified), or made of composite materials, or aluminum (minimum thickness - 1,0 mm).
- 7.2.10. Original engine bonnet lock - must be rendered inoperative or removed.
- 7.2.11. Safety pins (springs) - mandatory at least two for each engine bonnet and boot lid.
- 7.2.12. Front and rear bumpers – FREE construction and material but compulsory.
- 7.2.13. Front and rear bumper cross-beams - FREE.
- 7.2.14. Front and rear fenders - original (may be modified), or made of the composite materials, or aluminum (min thickness - 1,0 mm). It is allowed to remove outer panel of the original rear wing, situated below the rear side window, for a purpose of installing non original rear wing.
- 7.2.15. Front grilles – FREE construction and material but compulsory.
- 7.2.16. Other external decorative parts - FREE.
- 7.3. Windows, wipers, washers**
- 7.3.1. Windscreen can be original (can be heated) or made of polycarbonate plastic with a minimum thickness of 5,0 mm and an outer surface treated to be wear-resistant. It may be fitted with one or several transparent and colourless films on its outer surface.
- 7.3.2. It is allowed to use sun strip on the upper edge of the windscreen, on condition that it does not prevent the driver from seeing the signals and signs of the judges.
- 7.3.3. Windscreen wipers - FREE, but at least one active wiper is required.
- 7.3.4. Windscreen washer system - FREE.
- 7.3.5. Side windows - original (covered with a colorless protective film in accordance with FIA J art 253 - 11) or may be replaced with transparent polycarbonate plastic (min thickness - 3,0 mm). In case of the plastic glazing in the front doors, windows must be fitted in such a way that they can be removed without the help of tools. *Example: windows may be placed in the original upper girth of the door and mounted on the bottom with brackets, rivets, bolts.* The attachment of other side windows (including windows of front doors made of composite doors) is free.
- 7.3.6. The rear window can be original or made of polycarbonate plastic with a minimum thickness of 3,0 mm. The attachment of the rear window is free.
- 7.3.7. Rear window wiper - FREE.
- 7.3.8. Rear window washer system - FREE.
- 7.3.9. Window vents. For safety reasons, it is recommended to install airvents in the plastic windows of the both front doors. The shape of the vent opening is free (recommended minimum size of 90 cm²). Airvents can also be installed in the rear windows and the spaces between the upper edge of the rear door frame and the window.
- 7.3.10. Tinting of the windows (including the silver film) is prohibited.
- 7.3.11. Due to ventilation its allowed to open the front windows by 1/5 of the opening during the race.
- 7.4. Rear-view mirrors.**
- 7.4.1. Side view mirrors must be fitted on both sides of the car. The reflecting surface of each mirror can not be less than 90 cm².
- 7.4.2. An inside rear-view mirror - compulsory, except for cars with the originaly closed visibility through the rear window.

7.5. Aerodynamic elements and underguards

7.5.1. Aerodynamic elements – FREE, but must be situated within the perimeters marked in the picture 1. A – for all cars, B – for coupe, sedan, cabrio, C – for hatchback, wagon.

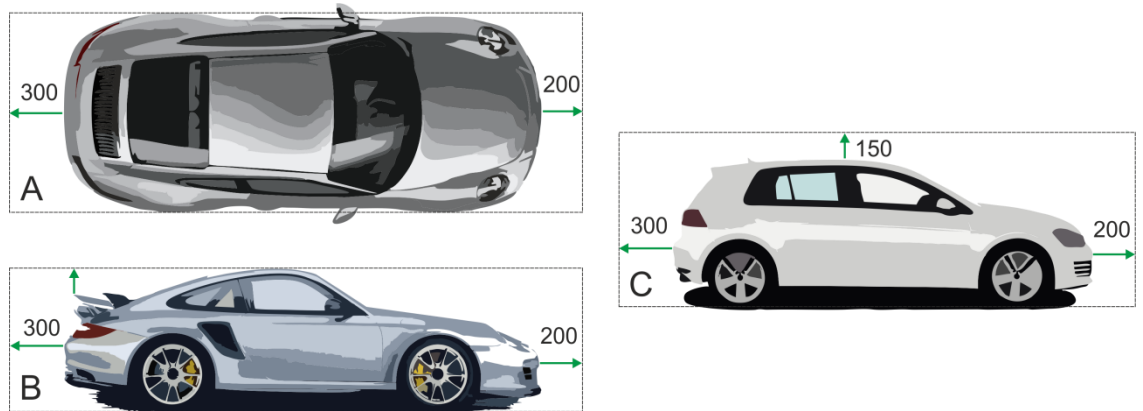

7.5.2. Aerodynamic elements may only be adjusted with the help of the tools.

7.5.3. Underguards - FREE.

7.6. Interior

7.6.1. Main condition - the cockpit of the car can not have open cavities with sharp, protruding edges that could injure the driver during an accident.

7.6.2. If any of the following - fuel tank, fuel catch tank, liquid-filled battery, fuel pumps, liquid (oil) tanks (except for water and window washer tank) – are installed in the cockpit (including open luggage compartment), they must be separated from the driver by a non-flammable, fluid-tight firewall or container.

7.6.3. Instrument panel - serial (may be modified) or made in the form of the serial panel from other materials.

7.6.4. Supplementary instruments (gauges, meters, sensors) - FREE, however, it is prohibited to install mechanical instruments for engine lubrication and cooling system according to paragraph 16.

7.6.5. Horn - FREE.

7.6.6. Onboard cameras and radio – allowed, but must be securely fixed either on the roll cage, or on the part of bodyshell.

7.6.7. Other interior parts - FREE.

7.7. Towing eyes

7.7.1. Towing eyes (min inner diameter – 60 mm) - must be fitted in the front and in the rear. Towing eyes made from soft (belt, etc) materials are strongly recommended.

7.7.2. Towing eyes must be clearly visible (colored yellow, red or orange) or (and) clearly marked.

7.8. Air jacks or similar car lifting systems – allowed.

8. ENGINE

- 8.1. Only internal combustion engines are permitted. Not more than one engine may be mounted on a car.
- 8.2. Motorcycle engines are prohibited, even if they were serially fitted into a model of a production car. The use of BMW S54 reduced capacity engines in class BTC2 and BTC3 are forbidden.
- 8.3. Cylinder block **must come from the engine of serially produced road car** (can be modified).
Example: the MITSUBISHI cylinder block can be mounted on the BMW body.
- 8.4. Cylinder diameter and piston stroke can be changed.
- 8.5. Due to engine repairs (original repair piston sizes) it is allowed to exceed the original geometric engine capacity limit by up to 2%. In such cases, the original geometric capacity is deemed to have not changed and this does not cause the car to be moved to another class or (and) weight category.
- 8.6. Crankshaft - FREE, but the number and type of the bearings must be retained.
- 8.7. Conrods and pistons (incl rings and pins) - FREE.
- 8.8. Crankshaft main and conrod bearing shells - FREE.
- 8.9. Flywheel and pulleys - FREE.
- 8.10. Cylinder head - FREE, but original layout of the camshaft (-s) and number of the valves must be retained. The use of BMW S54 cylinder head in class BTC2 and BTC3 is forbidden.
- 8.11. Valves and springs - FREE.
- 8.12. Valve drive (rocker arms, tappets) - FREE.
- 8.13. Camshaft (-s) - FREE. ~~Except for BMW S50B30 engine in class BTC3, where original camshafts may only be used (INTAKE – 3219618, EXHAUST – 3219518).~~
- 8.14. Camshaft sprocket gear (-s), pulleys, variable timing adjusters - FREE.
- 8.15. Camshaft drive (chains, belts, tensioners, sliders) - FREE.
- 8.16. Cylinder head gasket and screws - FREE.
- 8.17. Engine mounting - FREE.
- 8.18. Lubrication system - FREE, but its components can not be fitted in the cockpit.
- 8.19. Cooling system - FREE, but its components, with the exception of interior heating, can not be fitted in the cockpit. It is permitted to remove or modify the heating system, however it is necessary to ensure protection against fogging of the windscreen. Cooling system must be filled with water only (including specialia additive).
- 8.20. Engine fuel - air supply system.
 - 8.20.1. Composition of the mixture – atmospheric air + fuel delivered from one tank of the car. Water as an additive may be used (water injection).
 - 8.20.2. Air inlet can not be placed in the cockpit.
 - 8.20.3. Air filter box (with diffusers) - FREE.
 - 8.20.4. Air filter - FREE.

- 8.20.5. Air intake lines (pipes, hoses) - FREE. ~~Except for BMW S50B30 engine in class BTC3, where original airbox may only be used.~~
- 8.20.6. Air flow meter – FREE.
- 8.20.7. Throttle body (TB) or individual throttle bodies (ITB) – FREE ~~with an exceptions:~~
- ~~• for BMW S50B30 engine in class BTC3, the internal diameter of ITB ports is limited to max 50 mm. Diameter of TB port is FREE;~~
 - ~~• In class BTC2 the internal diameter of TB is limited to max 64 mm. In the case of a greater diameter TB's or ITB's all air flow sucked into the engine (including flow sucked through the idle valve) must pass restrictor with an internal diameter of max 64 mm;~~
 - ~~• Restrictor(-s) must be located between the air filter and the TB (ITB). Restrictor must be produced from a single mass material.~~
- 8.20.8. Intake manifold - FREE.
- 8.20.9. Turbocharger (-s) – FREE with an exceptions:
- Turbocharger is forbidden in classes BTC1 and BTC2;
 - Turbocharger is forbidden for petrol engine in class BTC3;
 - Two parallel turbochargers may be used on engines, which are produced in a factory with a such composition and with original turbochargers in use;
 - Compressor impeller diameter A is limited to max 48 mm or / and internal diameter of intake channel A1 is limited to max 50 mm (tolerance of +1.0 mm is accepted) in all classes (except for GT PRO). In the case of non compliance, intake air restrictor may be used (point 8.20.10).
- 8.20.10. Intake air restrictor:
- Max internal diameter (d) of the restrictor – 50 mm. Max outer diameter (D) - FREE;
 - All air flow sucked into the engine (including flow sucked through the idle valve) must pass restrictor which must be mounted on the compressor housing according to FIA J art 255 – 5.1.8.3.

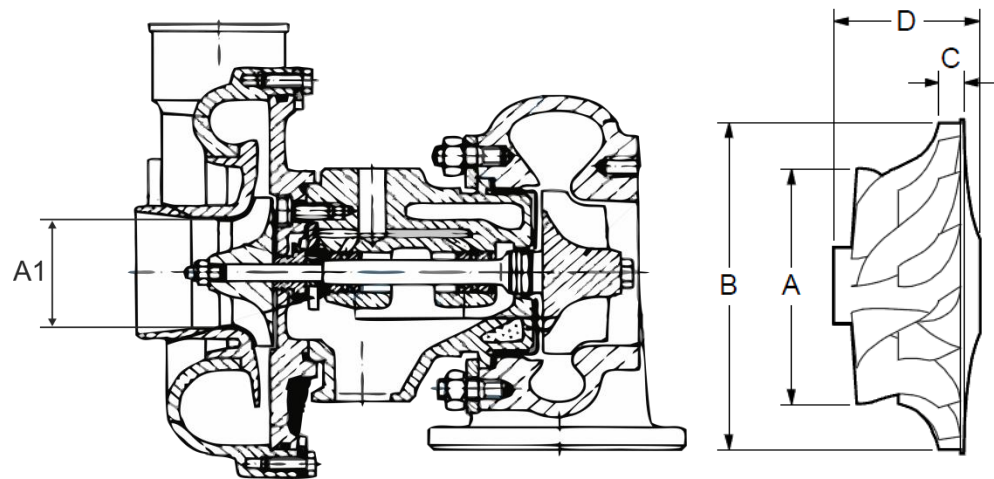

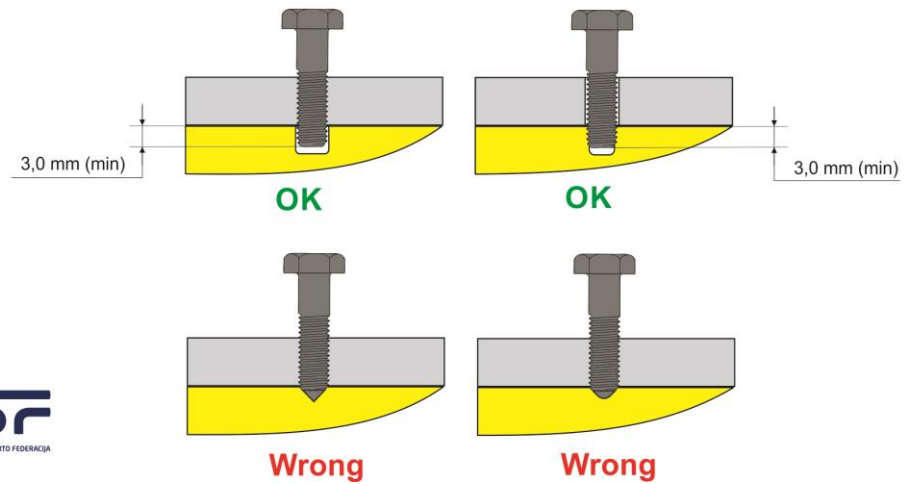
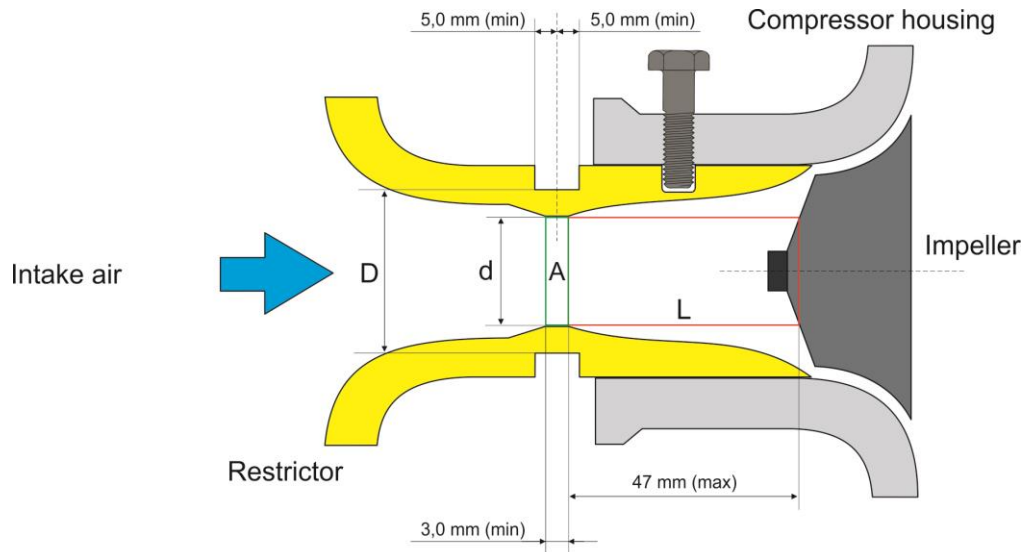

8.20.11. Supercharger (mechanical compressor):

- Prohibited in classes BTC1, BTC2 and BTC3;
- Original in class BTC4;
- FREE in classes GT AM and GT PRO.

8.20.12. Intercooler - FREE. Internal capacity not more than 18 L in classes BTC3 and BTC4. Water spray cooling is allowed.

- 8.20.13. Injectors - FREE.
- 8.20.14. Carburetors – FREE.
- 8.20.15. Fuel circuit, filters and catch tank - FREE. Installation according paragraph 16. Use of automatic cut-off valve on the fuel circuit is recommended. Installation according FIA J 253 - 3.3.
- 8.20.16. Fuel pump (-s) - FREE. Fuel pump(-s) must operate when the engine is running, except during the starting process.
- 8.20.17. Fuel tank (-s) - original or (and) FIA **or SFI** homologated fuel tank (an extension of the homologation for 5 years, without approval of the manufacturer, is allowed). Installation according to FIA J art 252 - 9.6 and FIA J art 253 - 14. Max two tanks, not exceeding a sum capacity up to 120 litres (+5% tolerance permitted) may be used.
- 8.20.18. Fuel tank ventilation system and roll-over valves - original. If the original ventilation system is dismantled, the new system and parts must comply with FIA J art 253 - 3.4.
- 8.20.19. The fuel filler neck or (and) homologated fuel filler connectors must not extend beyond the outer perimeter of the bodywork. Installation according to FIA J art 253 – 14.2.
- 8.20.20. Filler neck (except for filler connectors), fuel tank, fuel catch tank, filter(-s), pump (-s) must be outside the cockpit (points 2.2. and 7.6.2. of these regulations).
- 8.20.21. Liquefied or natural gas tanks (cylinders) - prohibited.
- 8.20.22. Fuel - FREE.
- 8.20.23. When using bio-ethanol (E85), the vehicle must be marked on both sides with E85 stickers, with no more than 200 mm above the rear wheel arches.
- 8.21.** Exhaust system.
 - 8.21.1. All engine exhaust gases must enter the main exhaust pipe and exit it at the end of pipe.
 - 8.21.2. The end (exit) of the exhaust pipe must be situated within the perimeter of the car and less than 100 mm from this perimeter, in the rear or on the side of the car, behind the front wheel. No parts of the chassis should be used to evacuate exhaust gasses.
 - 8.21.3. Exhaust manifold - FREE.
 - 8.21.4. Other parts of the exhaust system - FREE.
 - 8.21.5. Maximum noise level: 105 dB (A) at 6000 RPM. This measurement will be taken at a distance of 0,5 m and at a 45 degree angle to the point of exit of the exhaust.
- 8.22.** Ignition system - FREE.
- 8.23.** Engine ventilation system – FREE. In case of an open type sump breather, the system must be equipped in such a way, that the oil flows into the catch tank, with a minimum capacity of 2,0 liters. It is recommended to follow the requirements of FIA J art 255 – 5.1.14.
- 8.24.** Engine management.
 - 8.24.1. Engine control unit (ECU) and software - FREE.
 - 8.24.2. Engine wiring harness - FREE.
 - 8.24.3. Additional sensors are allowed.
- 8.25.** Other engine parts and systems - FREE.

9. TRANSMISSION

- 9.1. The conversion from two-wheel drive to four-wheel drive and vice versa is allowed, even if these gear types were not provided for in the base model.
- 9.2. Clutch - FREE.
- 9.3. Clutch drive (pedal, master and slave cylinders) - FREE.
- 9.4. Clutch fluid lines may be replaced by aviation type tubes or hoses. It is permitted to run these lines inside the cockpit according to paragraph 16.
- 9.5. Gear box - FREE. ~~The use of dog type (incl. sequential) or automatic (incl. DSG, DCT, SMG, ect) gear boxes in class BTC3 is forbidden (except for BEC4H series). As an exception for non-compliance of this point in BaTCC and NEA series, the ballast of 100 kg must be added. For cars with engines less than 2500 cm³ - min weight 1280 kg, for cars with engines more than 2500 cm³ - min weight 1330 kg.~~
- 9.6. Position and orientation of the gearbox - FREE.
- 9.7. Gear ratios - FREE.
- 9.8. Reverse gear - mandatory.
- 9.9. Gear change system - FREE.
- 9.10. Central differential (incl. management) - FREE.
- 9.11. Propshafts (incl. CV joints) - FREE.
- 9.12. Driveshafts (incl. CV joints) - FREE.
- 9.13. Differential - FREE.
- 9.14. Limited slip differential systems - FREE.
- 9.15. Other transmission parts - FREE.

10. BRAKING SYSTEM

- 10.1. Double circuit brake system, operated with one pedal - compulsory. The pedal must normally control all wheels, but in the event of any type of brake failure, the pedal must brake at least two wheels.
- 10.2. Brake pedal and drive - FREE, but parts must be made of metal.
- 10.3. Brake light switch - compulsory with retained function.
- 10.4. Master cylinder(-s) (incl. fluid tank) - FREE. Fluid tanks made of flammable materials must be covered with a container if situated in the cockpit.
- 10.5. Brake booster - FREE.
- 10.6. Anti-lock braking system - FREE.
- 10.7. Brake calipers - FREE.
- 10.8. Brake discs - FREE.
- 10.9. Brake pads - FREE.
- 10.10. Hand brake - FREE.
- 10.11. Brake balance adjuster - FREE.
- 10.12. Brake lines may be replaced by aviation type tubes or hoses. It is permitted to run these lines inside the cockpit according to paragraph 16.
- 10.13. Brake cooling – FREE.
- 10.14. Other parts of the braking system - FREE.

11. STEERING

- 11.1.** If the series production car model has an all wheel steering system, it can remain, but can not be modified.
- 11.2.** Steering wheel - FREE.
- 11.3.** Steering wheel quick release system - recommended.
- 11.4.** Steering drive (shafts and their hinges) - FREE.
- 11.5.** Steering wheel lock - must be an inoperative or removed.
- 11.6.** Steering wheel position adjuster. The steering wheel position can only be adjusted with the help of tools.
- 11.7.** Steering rack - FREE.
- 11.8.** Steering rods (incl ends) - FREE, but can not be made of composite materials.
- 11.9.** Power steering (pump, motor, gear and fluid lines) - FREE.
- 11.10.** Other parts of the steering system - FREE.

12. SUSPENSION

- 12.1.** The operating principle of the suspensions - FREE.
- 12.2.** Wheel base - FREE.
- 12.3.** Springs (leaf springs, torsion bars) - FREE.
- 12.4.** Spring supports - FREE.
- 12.5.** Shock absorbers - FREE, however systems allowing adjustment of the shock absorbers during the driving are prohibited.
- 12.6.** Shock absorber (spring) top mounts (bearings) - FREE.
- 12.7.** Uprights (including bearings, hubs) - FREE.
- 12.8.** Wishbones, trailing arms - FREE, but can not be made of composite materials.
- 12.9.** Anti-roll bars (sway bars) and their connections with the suspension - FREE.
- 12.10.** Suspension joints (bushes, bearings) - FREE.
- 12.11.** Crossmembers - FREE, but modifications can not cause structural weakness.
- 12.12.** Suspension mounting points - FREE, however, the modification can not cause structural weakness.
- 12.13.** Other parts of the suspension - FREE, but they can not be made of composite materials.
- 12.14.** Ground clearance. No part of the car must touch the ground when tyres on one side are deflated. This test must be carried out on a flat surface under race conditions with driver onboard.

13. WHEELS

- 13.1.** Fenders (bodywork) must completely cover the wheels (incl. wheel studs) from the top. With the wheels straight (with no damages to suspension) the projection line „A“, lined with the side of the wheel, must cut through or touch the fender at the point „B“.

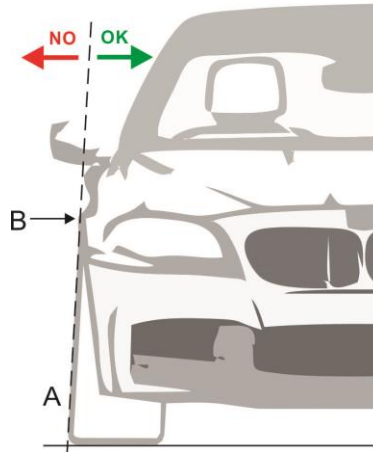

- 13.2.** Wheel fasteners. Serial fastening with bolts can be replaced by fastening with studs and nuts or axel fastening with one nut.
- 13.3.** Rims. Spacers between the rim and wheel hub – authorised.

13.4. Tyres:

BaTCC, NEA	BTC1	NANKANG AR1 205/50R15
BaTCC, NEA	BTC1 (LADA)	NANKANG AR1 205/60R13
BaTCC, NEA	BTC2	NANKANG AR1 225/45R17
BaTCC, NEA	BTC3	NANKANG AR1 235/40R17 or 235/40R18
BaTCC	BT4, GT AM, GT PRO	FREE
BaTCC	GT AM (CAYMAN RS CLUBSPORT)	HANKOOK VENTUS
NEA	BTC4, GT AM	NANKANG AR1 (size FREE)

- The number of tyres – according to event regulations.
- Any heating (with a help of electrical or fuel power) or chemical treatment of the tyres is prohibited.
- For a wet race conditions it is allowed to modify tyre pattern in a free manner.

14. LIGHTING AND ELECTRICAL EQUIPMENT

- 14.1.** External lighting must be original or other lights can be fitted if they meet the following minimum requirements:
- One pair of front (low beam) lights (55W or equivalent LED);
 - One pair of red rear lights (10W or equivalent LED);
 - One pair of red brake lights (21W or equivalent LED);
 - One red rear rain (fog) light (21W or equivalent LED);
 - Two pairs of indicator lights – one pair in the front, one - in the rear (21W or equivalent LED);
 - Max two pairs of the front additional lights may be used;
 - Recognition lights may be installed (max 5W or equivalent LED).
- 14.2.** Alternator - FREE.
- 14.3.** Starter - FREE.
- 14.4.** Battery - FREE. If battery is moved from its original location, it must be installed according to FIA J art 255 - 5.8.3. Battery in the cockpit must be dry type battery and it must be installed behind the line of the driver seat.
- 14.5.** Wiring harness - free, but must be installed according to paragraph 16.
- 14.6.** Other lighting and electrical equipment - FREE.

15. GENERAL CIRCUIT BREAKER

- 15.1.** The general circuit breaker – compulsory. It must cut out all electrical circuits from the battery and switch of the engine. Installation and use according to FIA J art 253 - 13.

16. LINES (HOSES, PIPES) AND ELECTRICAL CIRCUITS

- 16.1.** Obligatory application if the series fitting is not retained.
- 16.2.** Oil, fuel, and hydraulic lines must be protected externally against any risk of deterioration (stones, corrosion, mechanical breakage, etc) and internally against any risk of fire and deterioration.
- 16.3.** Any lines containing cooling water (fluid) or lubricating oil must be outside the cockpit.
- 16.4.** Lines containing fuel or hydraulic fluid may pass through the cockpit, but without any connectors inside the cockpit, except on the front and rear bulkheads and on the braking and clutch circuits.
- 16.5.** In case of flexible lines, threaded, crimped, or self-sealing connectors and an outer braid resistant to abrasion and fire must be used.
- 16.6.** In places where lines or wires pass through firewalls, the edges of the holes must be covered with protective materials.
- 16.7.** No lines or wiring, no cables or lines of the fire extinguishing system may pass between the bodywork and outer perimeter of the roll cage.
- 16.8.** Additional information FIA J art 253 - 3.

17. SAFETY CAGE

17.1. The fitting of the safety cages is compulsory. It may be either:

- Homologated (certified) by FIA or ASN. The homologation form or safety cage certificate must be present at every race event;
- Fabricated in compliance with the requirements of the FIA J art 253.8 (2020). The national safety cage certificate must be present at every race event.

17.2. Minimum safety cage structure (for cages built after 31.12.2020):

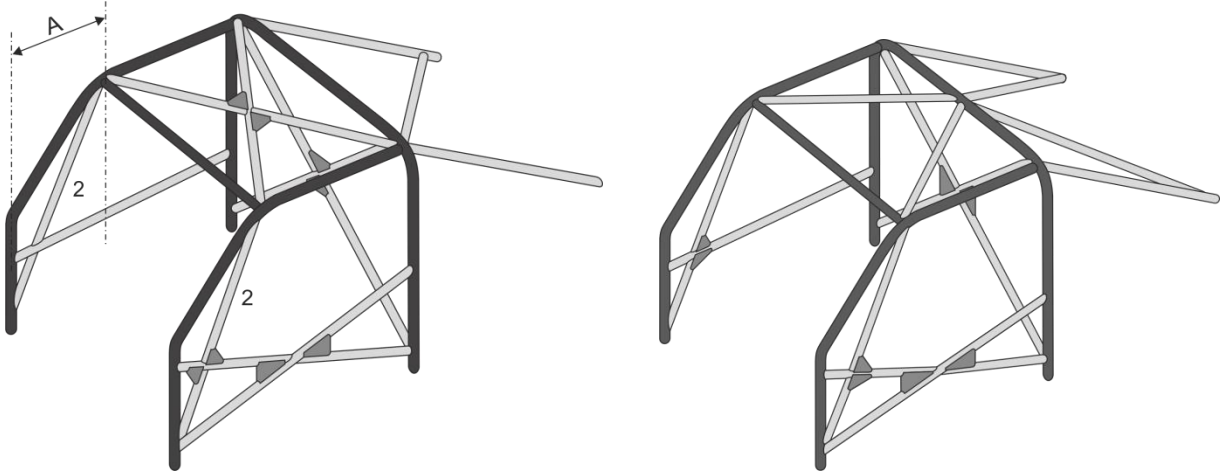

17.3. Places (marked red in picture) , where the driver's helmet can come into contact with the safety cage during an accident, must be covered with a padding in accordance with FIA 8857-2001 standard. Padding must be fixed tightly to the safety cage bar, with no possibility to move it or to turn it on the radius of the bar.

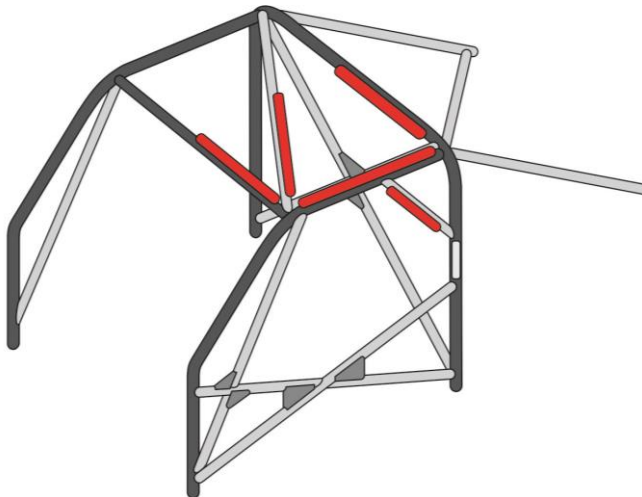

18. SAFETY HARNESS, SEATS, WINDOW NET AND DRIVERS EQUIPMENT

- 18.1.** Safety harness. Six point, mechanically or (and) chemically undamaged safety harnesses in compliance with FIA 8853/98, 8853-2016 standards must be used. Installation and use according to FIA J art 253 - 6.2 / 6.3. No homologation extensions allowed. Elastic devices attached to shoulder straps are prohibited.
- 18.2.** Belt cutter - compulsory. It must be easily accessible for the driver when seated with his harnesses fastened.
- 18.3.** Seat. Mechanically or (and) chemically undamaged seat in compliance with FIA 8855-1999, 8855-2021, 8862-2009 standards must be used. Installation and use according to FIA J art 253 - 16. **Homologation extension of 5 years, without approval of the manufacturer, allowed.**
- 18.4.** Window net – mandatory. Installation and use according to FIA J art 253 – 11. The use of hand straps instead of a net is authorized. The installation and use of this equipment must ensure the protection of driver's hands and head.
- 18.5.** Drivers equipment. Clothing (overalls, shirt, trousers, socks, balaclava, shoes, gloves) in compliance with FIA 8856-2000, 8856-2018 standards must be used.
- 18.6.** Helmet. Helmet in compliance with **(FIA (SNELL) SA2010 / SAH2010 + 8858-2002, SA2010 / SAH2010 + 8858-2010, 8858-2002, 8858-2010, 8860-2004, 8860-2010, 8859-2015, 8860-2018)** standards must be used. Any additional equipment (cameras, camera-holders) that are not provided by the manufacturer - prohibited.
- 18.7.** Head restraint systems (HANS, HYBRID). Head restraint systems in compliance with FIA 8858-2002, 8858-2010 standards must be used.

19. FIRE EXTINGUISHING EQUIPMENT

- 19.1.** Fire extinguishing systems - recommended. Installation according to FIA J 253 - 7.2.
- 19.2.** Manual fire extinguisher – mandatory (min 2 kg), if no fire extinguishing system installed in the car. Manual fire extinguisher must be easily accessible for the driver. Installation according to FIA J art 253 - 7.3.

20. TRANSPONDER (for BEC4H series)

- ~~**20.1.** Every team has to buy or rent X2 Transponder Car Direct Power device. More information available: +370 (620) 70 723 or info@timingteam.lt~~